

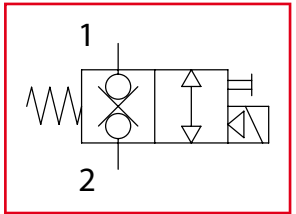

EDT

Valvole a comando elettrico 2 vie
2 ways cartridge electric valves



LEHENGOK, S. A.



Dati tecnici Technical data	
Viscosità fluido Fluid viscosity	10-500 mm ² /s 45 to 2000 ssu (6 to 420 cSt)
Classe di contaminazione Filtration	ISO code 16/13 SAE class 4 or better
Temperatura fluido Fluid temperature	-20°C +80°C -4°F +176°F
Temperatura ambiente Ambient temperature	-20°C +50°C -4°F +122°F

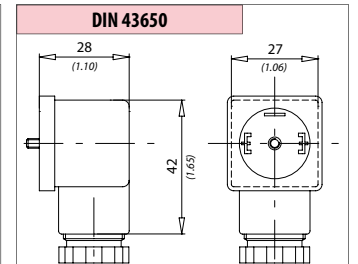
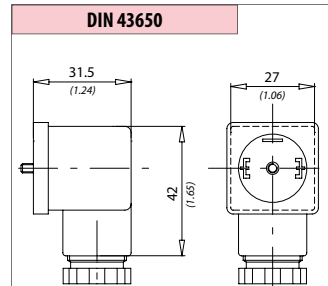
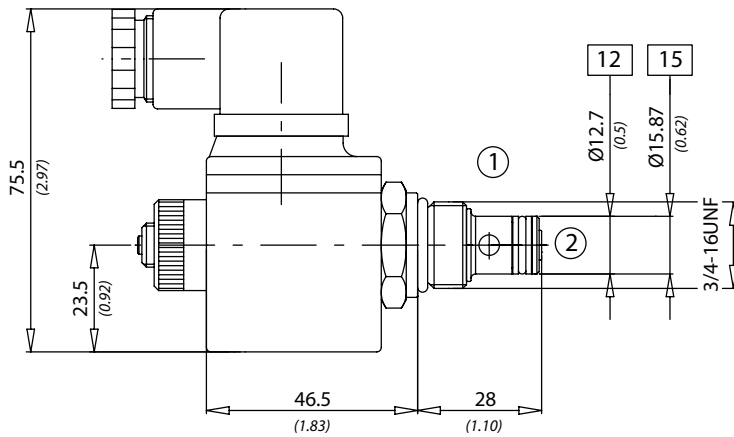
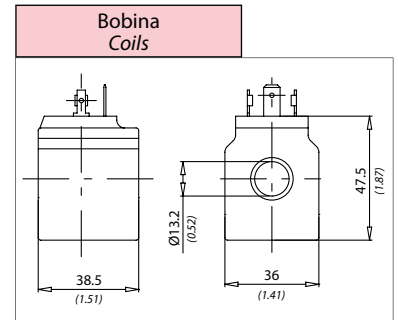

**Connettore con raddrizzatore
Connector with rectifier**

Portata nominale contatti Nominal current	10 A
Portata max contatti Max operating current	16 A
Resistenza contatti Contact resistance	≤ 4m Ohm
Sezione max conduttori Max conductors cross-section	1,5 mm ²
Portacontatti, dado Contact holder	PA
Tipo di serracavo Gland size options	Pg09
Diametro cavo Cable diameter	6-8 mm
Grado di protezione Protection class	IP 65 EN 60529
Classe di isolamento Insulation class	VDE 0110-1/89
Guarnizione Sealing material	NBR
Temperatura di esercizio Operating temperature	-40C +90C

**Connettore standard
Standard connector**

Tensione nominale Nominal voltage	AC - Max 250 V DC - Max 300 V
Portata nominale contatti Nominal current	10 A
Portata max contatti Max operating current	16 A
Resistenza contatti Contact resistance	≤ 4m Ohm
Sezione max conduttori Max conductors cross-section	1,5 mm ²
Protezione Housing	PA (+G)
Tipo di serracavo Gland size options	Pg09
Diametro cavo Cable diameter	6-8 mm
Grado di protezione Protection class	IP 65 EN 60529
Classe di isolamento Insulation class	VDE 0110-1/89
Guarnizione Sealing material	NBR
Temperatura di esercizio Operating temperature	-40C +90C

**Caratteristiche tecniche
Technical performances**

Pressione max Max pressure	210 bar 3000 PSI
Portata max Max flow	22 l/min 6 Usqpm
Protezione Protection	IP65
Tolleranza di alimentazione Feeding tolerance	+ / - 10%
Inserimento Energizing time	ED 100%
Classe di isolamento Insulation class	H
Potenza assorbita in C.A. Absorbed power in A.C.	20 VA
Potenza assorbita allo spunto Absorbed power at pickup	28 VA
Potenza assorbita in C.C. Absorbed power in C.C.	18 W
Peso approssimativo Approx weight	0,28 Kg 0.61 lb
Coppia di serraggio Tightening torque	25-30 Nm 19-22 lbf ft
Cavità Cavity	SAE 8/2

[mm
(Inches)]

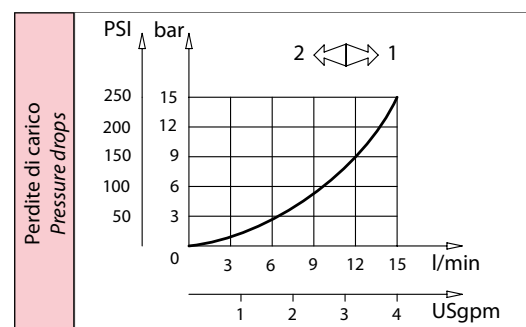

Le prove sono state eseguite con solenoidi a temperatura di regime, sottoalimentati del 10% rispetto al valore nominale.
Tests carried out with solenoids at their working temperature, with a supply voltage 10% below the nominal value.

**Codice ordinazione
Ordering code**

EDT6 - X - Y - K - Z

X	Schema - Scheme	Y	Voltaggio / Voltage
EDT6	Normalmente chiusa + emerg. Normally closed + emerg.	012DC	12 V (DC)
		024DC	24 V (DC)
		024RAC	24 V (RAC)
Z	Optional	110RAC	110 V (RAC)
		220RAC	220 V (RAC)
D	Dado di chiusura	K	Dimensione / Size
		12	Ø 12,7
		15	Ø 15,87